

• SPECIFICATION •

• 4272 - IO TWO HOLE SINK MIXER C SPOUT WITH CROSSHEAD HANDLES AND RINSE

- Handcrafted in the UK
- 1/4 turn ceramic disc flow control
- Vernier insert for accurate handle alignment
- Unique handle construction with integral bearing ring
- Flexible connectors for easier installation
- Single flow spout
- Supplied with 15mm double check valves
- Ideally installed in equal pressure systems

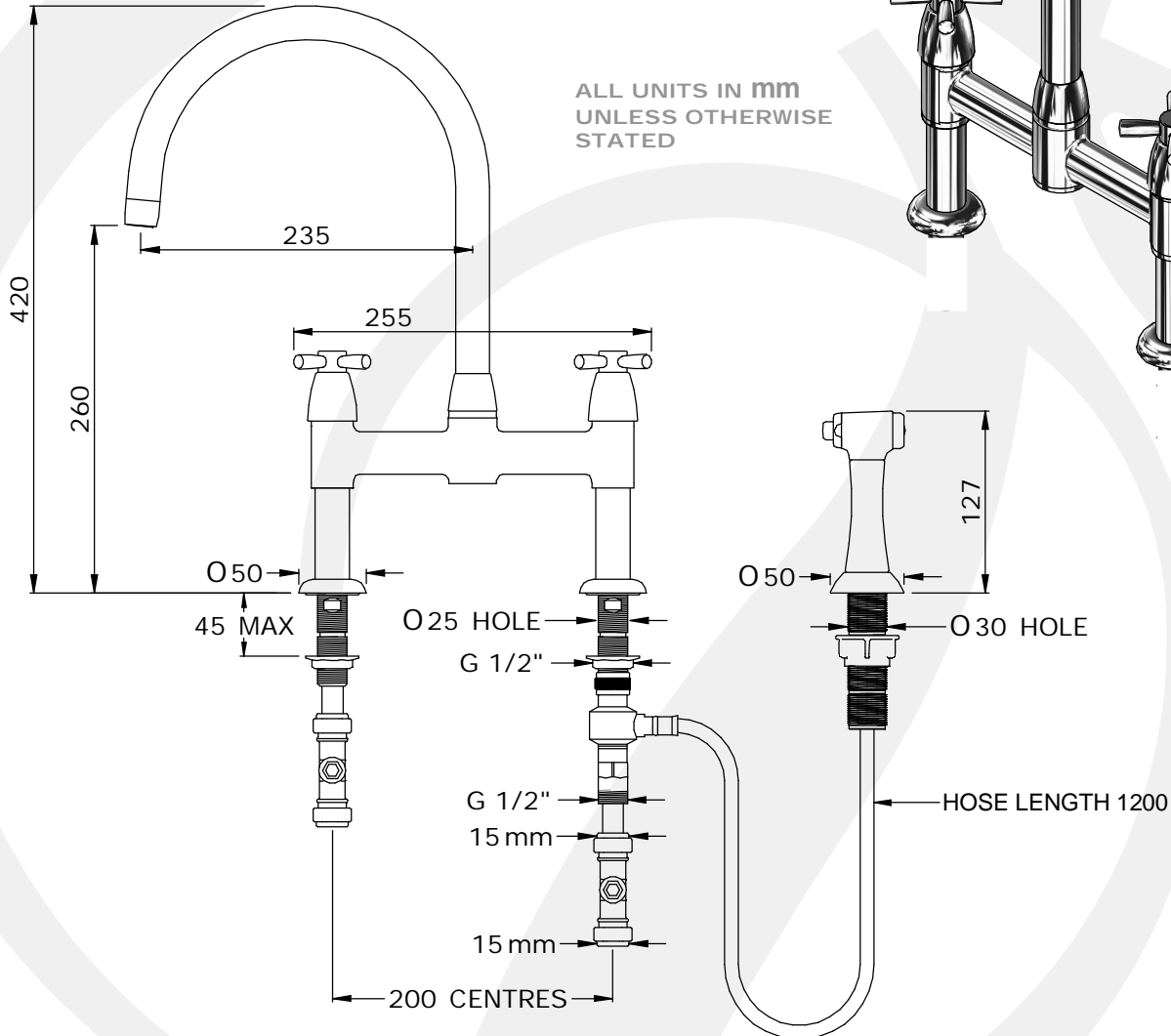
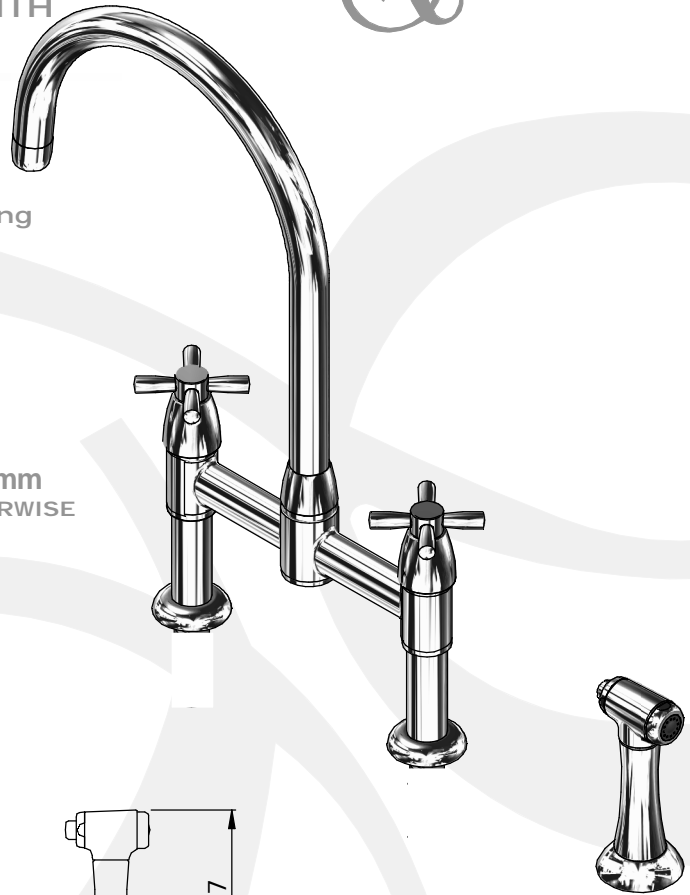

Available Finishes:

- Chrome
- Nickel
- Pewter
- Polished Brass
- Satin Brass
- Aged Brass
- Gold
- English Bronze

• Temp Range:
Min 1°C / 34°F
Max 70°C / 158°F

• Recommended Working Pressure:
Min 1bar / 15psi
Max 5bar / 75psi

• Packed Weight:
4.1 kg

Available Options:

- 5.7L/min regulated spout (Prefix AR.)
- Non Rinse version
- Matching soap dispenser

Flow Rates:

- 1 Bar: 6.2 L/Min
- 2 Bar: 9.9 L/Min
- 3 Bar: 12.7 L/Min